

# The role of the intermediary in an e-only world

Mark Carden

Executive Vice President, Global Sales and Marketing  
Publishing Technology

# About Publishing Technology ~~(slide 1 of 12)~~

## Enterprise Applications

- Software to manage the publishing enterprise
- Supply chain and fulfilment applications

## Online Solutions

- Online research portal
- Online publishing platform
- Digital asset exploitation

## Market Communications

- Research services
- Marketing services
- Sales representation and content sales

# Who is here today

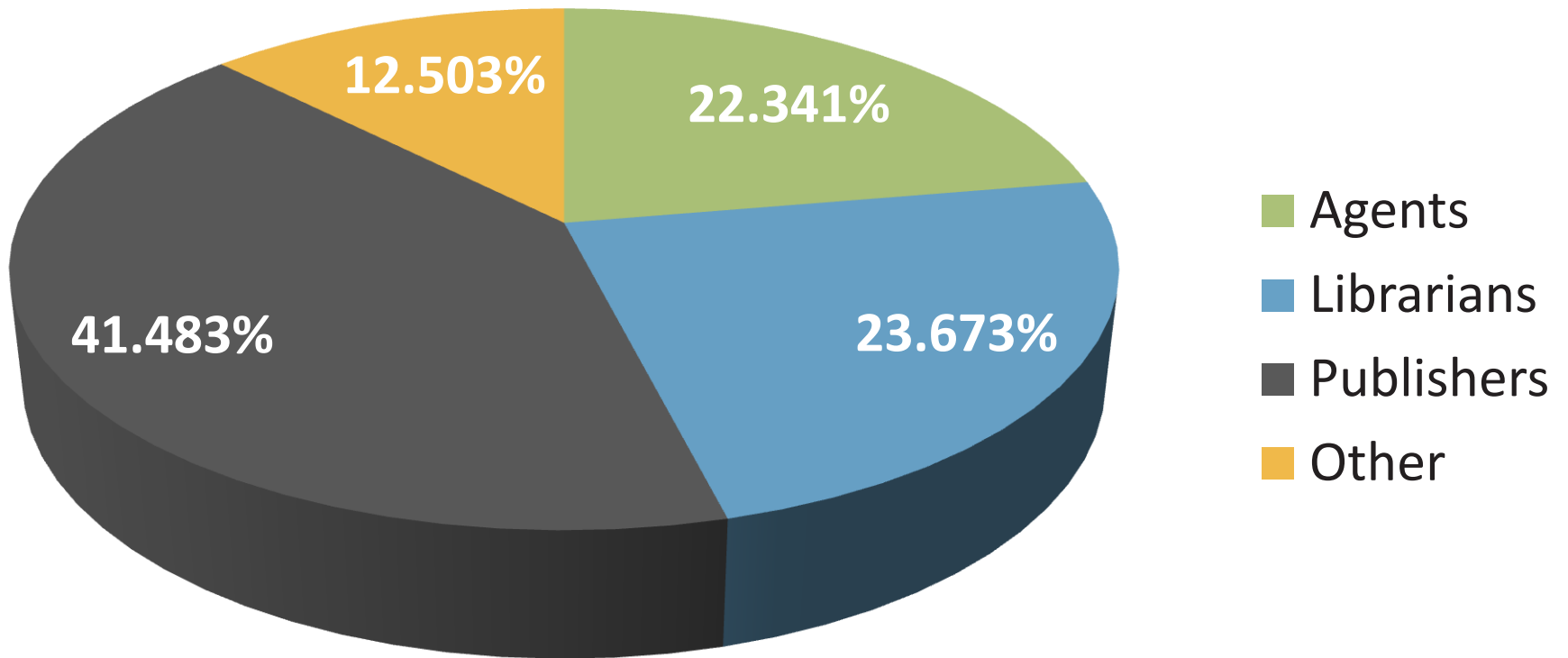

# Who is here today

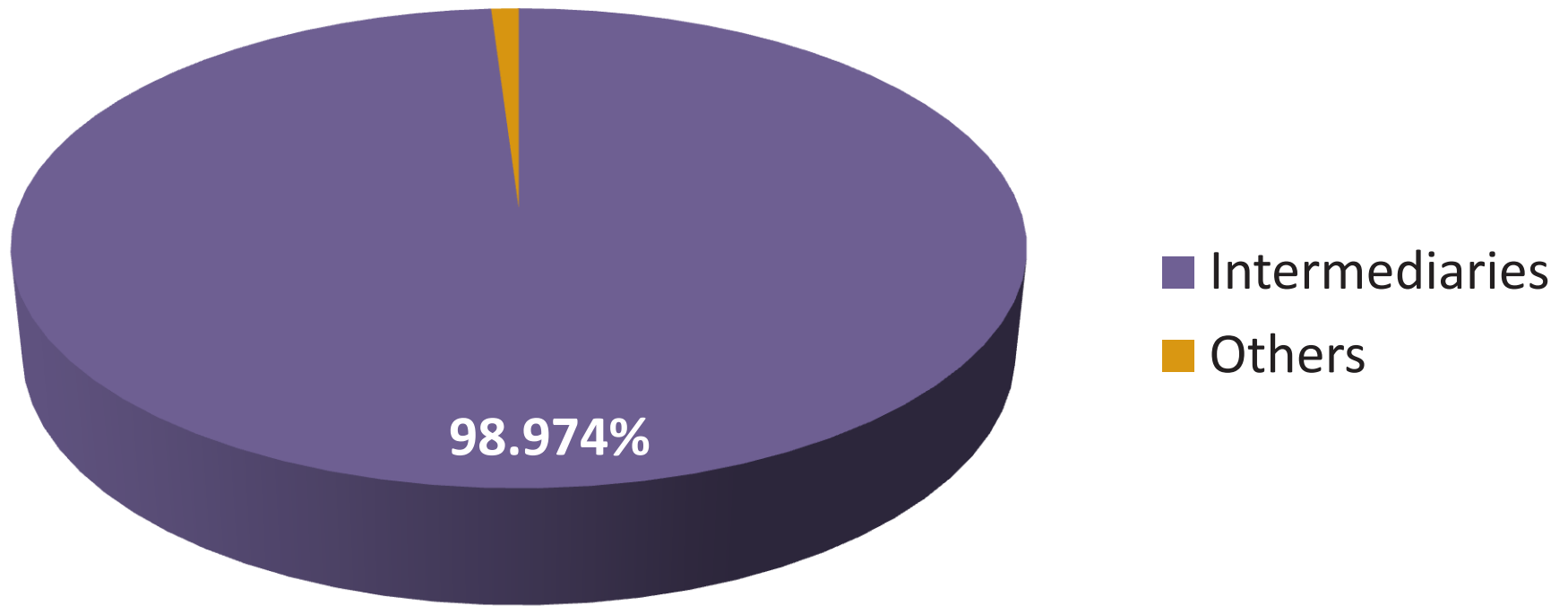

# Some intermediaries



**match.com**  
START YOUR LOVE STORY

**FedEx**

 **HM Revenue  
& Customs**



[http://blog.sleepio.com/wp-content/uploads/2010/05/stock\\_exchange.jpg](http://blog.sleepio.com/wp-content/uploads/2010/05/stock_exchange.jpg)  
<http://www.comparenow.com/blog/travel-insurance/holidaymakers-missing-out-on-best-travel-insurance-deals.html>  
<http://birchington.blogspot.com/2011/01/missing-meerkat.html>  
<http://www.match.com>

# The 'bow tie' model

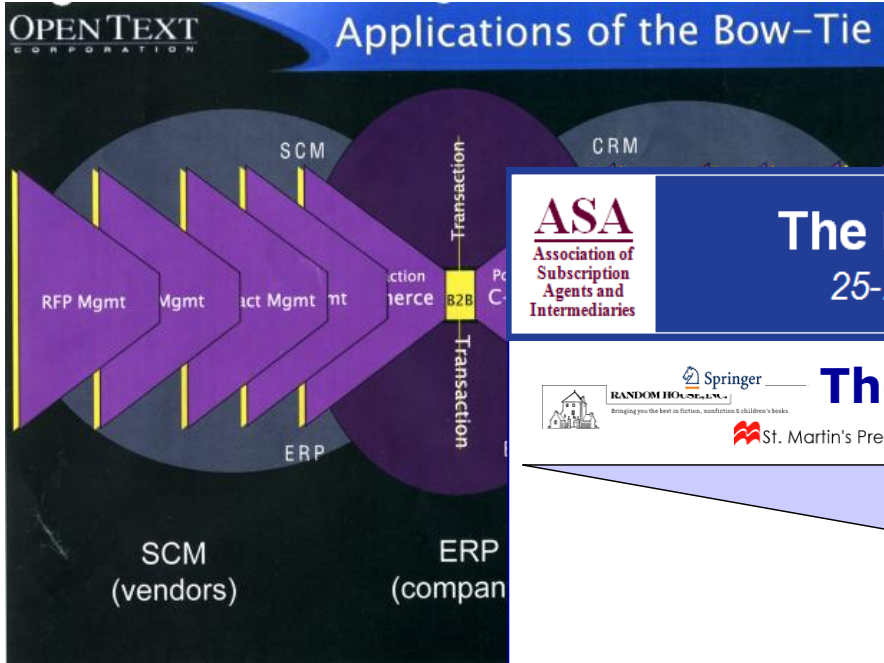





**ASA**  
Association of  
Subscription  
Agents and  
Intermediaries

## The Explosion of E-Resources

25-26 February 2008 RCN, London



**ASA**  
Association of  
Subscription  
Agents and  
Intermediaries



### Thousands of Publishers

**ASSET MANAGEMENT  
AGGREGATION  
DISTRIBUTION**

*Expertise  
Relationships  
Technology*



### Millions of Consumers



# The multi-layer model

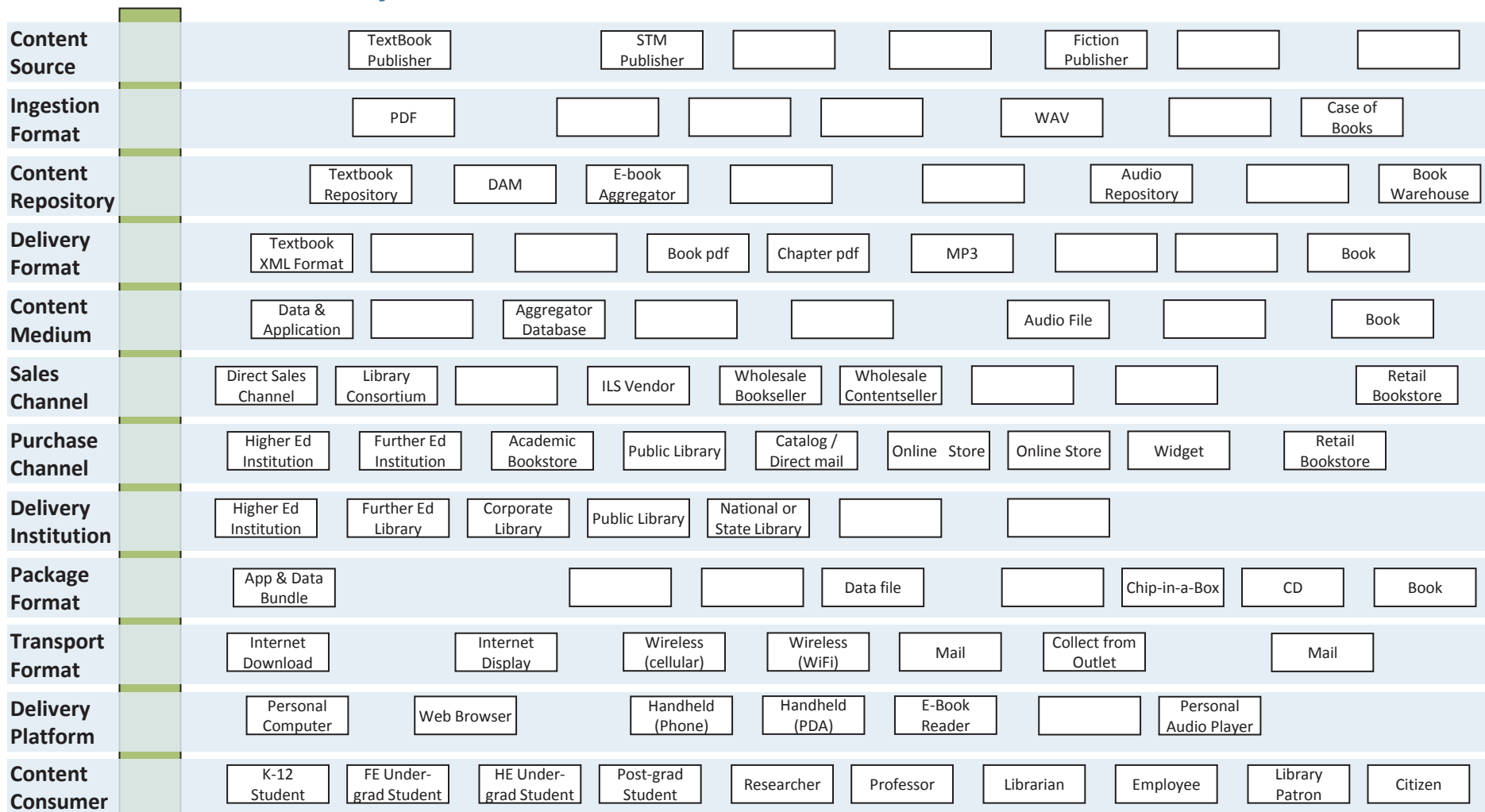

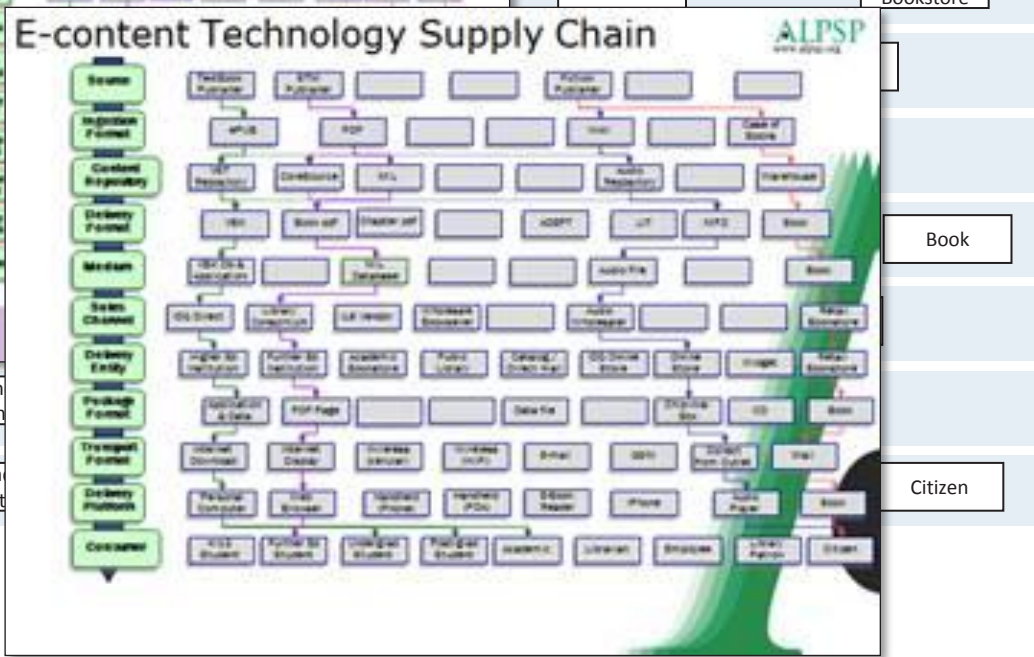
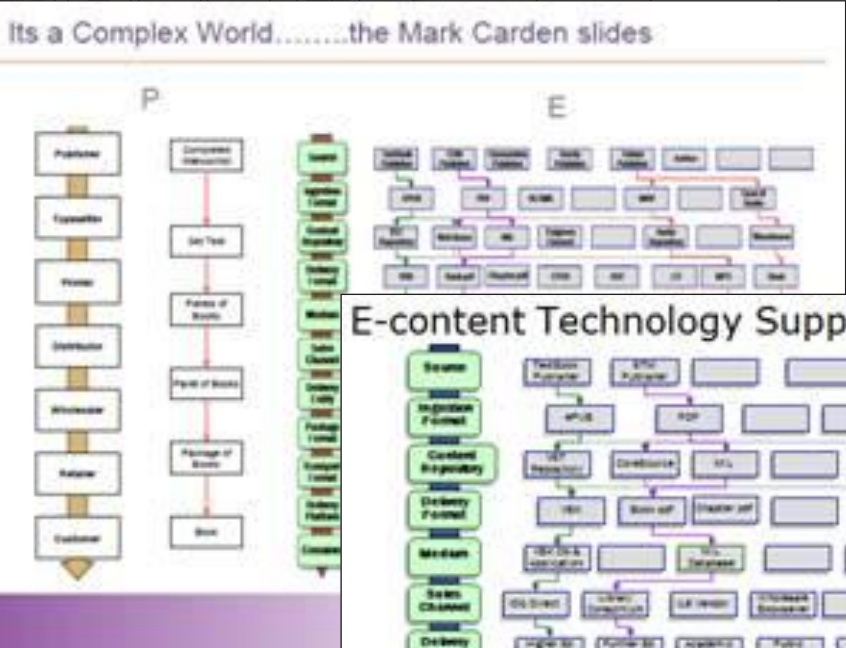
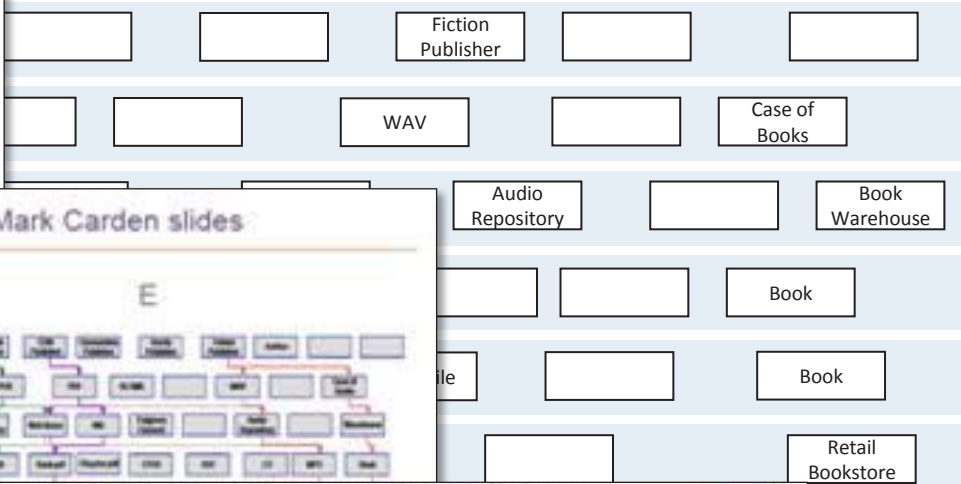
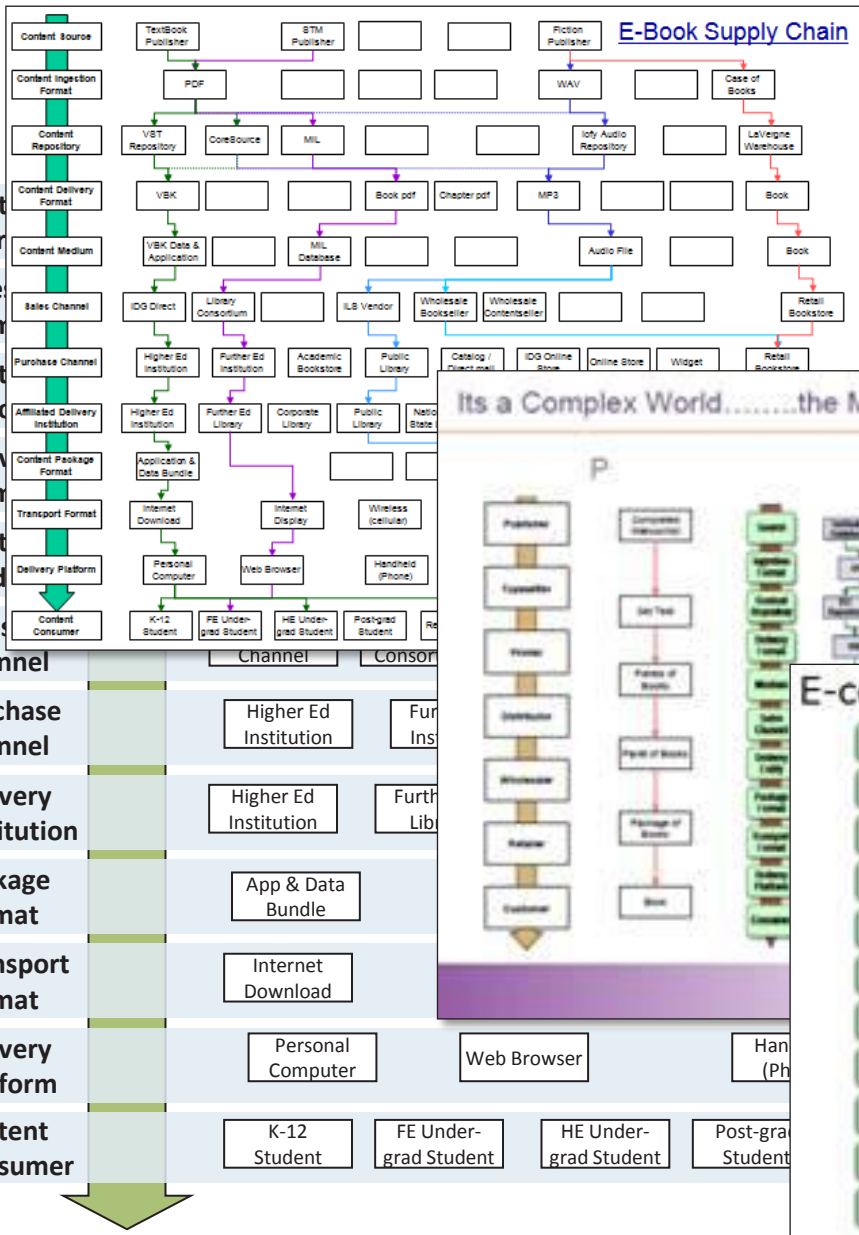

# Publishing intermediaries



# The role of the intermediary in an e-only world

## *Deconstructing the intermediary*

# Distributor



Shipping stuff from A to B,  
holding stuff in a warehouse,  
taking a fee

# Wholesaler / Reseller / Retailer



Buying it in,  
selling it on,  
taking a cut



# Broker/Agent

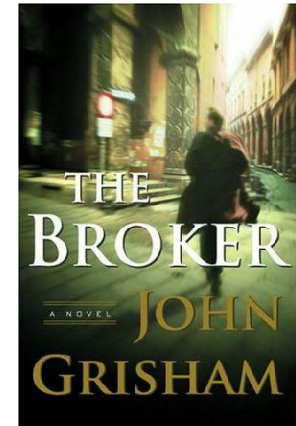
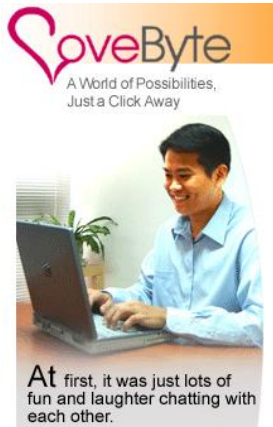

Facilitating transactions between two parties who would otherwise find it difficult to make contact or to transact effectively

# Consolidator / Aggregator

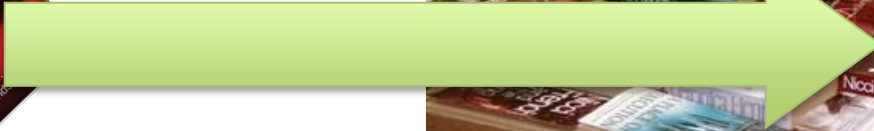
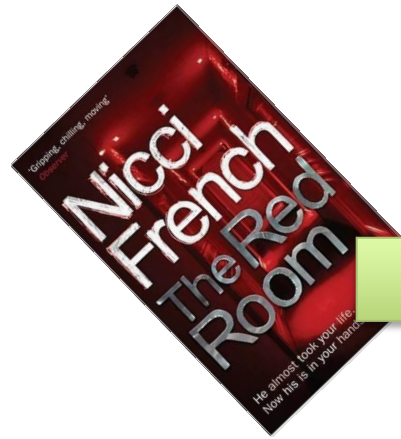

Consolidating/aggregating numerous disparate items from few or many sources into a pool of resources or a smaller number of units, as packages or on-the-fly

# De-consolidator

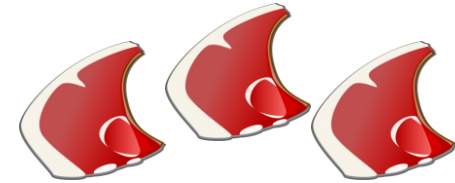
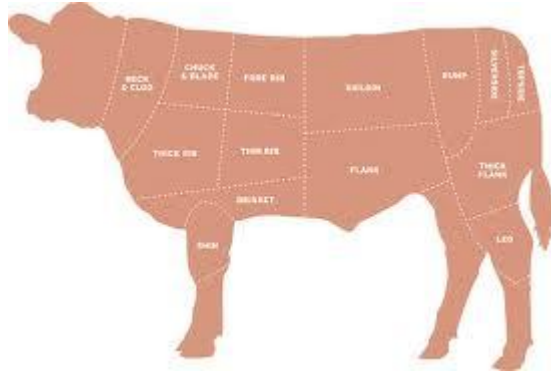

Breaking down large groups (homogeneous or heterogeneous) into smaller groups or individual items



# Representative

Aggregating and amplifying the views of a collection or community of entities and representing their needs to another party or group



# Data-provider

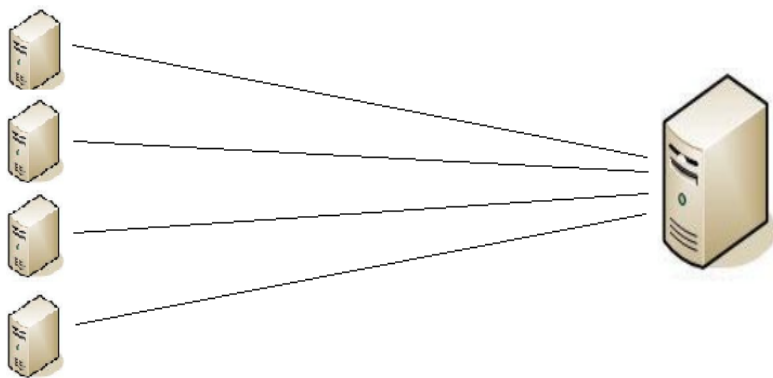

Providing information from operational repository or on individual transactions, institutional transactions and, most importantly, aggregated transactions

MARC records

Samples

Publisher database

Similar-institution profiles

Licence rules repositories

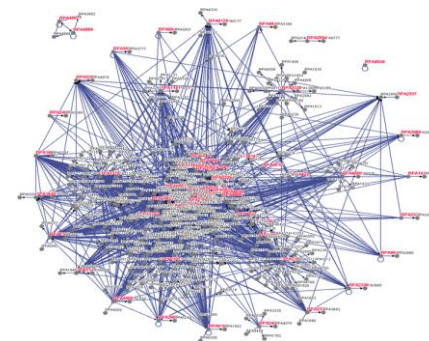
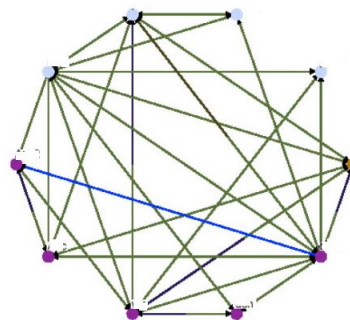

# Technology-provider

ingentaconnect™

  
OCLC™  
The world's libraries.  
Connected.

 **LEXCYCLE**  
REVOLUTIONS IN READING

 ScienceDirect

**swetswise**

 EBSCO  
NET

 talis®

AquaBrowser Library®  
search, discover, refine.

  
Summon™  
Web Scale Discovery

 UNC  
UNIVERSITY LIBRARIES

UNC-Chapel Hill Libraries Catalog

Online platform  
User interface  
Discovery  
Acquisitions  
ERM  
Licensing database

# Intermediaries

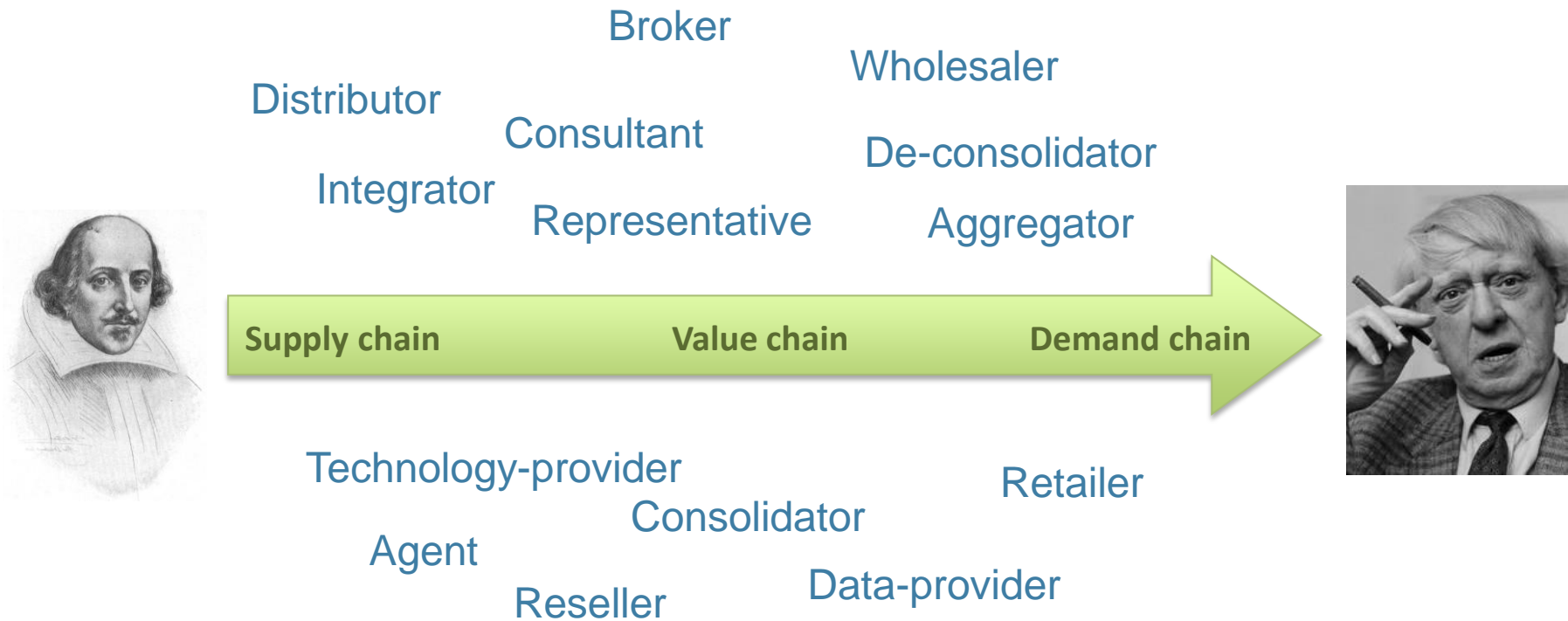

***Find the gap in the market  
See if there a market in the gap***

***Intermediaries can only be part of  
the value chain if their services  
make sense in the digital age***